

# BPM-TT Digital Pressure Sensor Assembly

## Product Overview

The BM-TT digital pressure sensor is an oil-filled, OEM pressure sensitive element isolated by a 316L stainless steel corrugated diaphragm. The chip adopts the internationally advanced high-stability and high-precision silicon piezoresistive chip. By applying new production processes and high-precision production and inspection equipment, the product has excellent stability.

Through the dedicated integrated circuit developed by the company for temperature compensation and nonlinear correction, it directly outputs standard current, voltage and digital signals. Digital output, low power consumption, easy to connect with various devices, simple assembly, and strong applicability.

This product can be widely applied to the detection of various fluid pressures.



## Product features

- ◆ It has the form of gauge pressure, absolute pressure and sealing pressure
- ◆ Isolated structure, suitable for a variety of fluid media
- ◆ Standard  $\Phi 19\text{mm}$  sensor universal size
- ◆ All stainless steel 316L material
- ◆ Standard current, voltage and digital signal output with high accuracy
- ◆  $-10\sim 70^{\circ}\text{C}$  wide temperature range compensation
- ◆ Full temperature zone 0.25% accuracy

## Structural material

- ① Diaphragm material: 316L, special customization
- ② Shell material: 316L
- ③ Pressure tap pipe material: 316L
- ④ Seal ring: butyl rubber, fluorocar-bon ring
- ⑤ Net weight: about 26g

## Performance parameters

Range	-100kPa ~ 0kPa ~ 10kPa...7MPa...70MPa
Output	4-20mA
Power supply	10-32V
Temperature compensation range	≤100kpa : 0-60°C
	> 100KPa : -10-70°C
Pressure type	Gague pressure,absolute pressure and sealing pressure
Accuracy	0.25%FS(10KPaaccuracy0.5%)
Hysteresis	0.03%FS
Repetitiveness	0.03%FS
Temperature drift	±0.25%FS(-10°C~70°C)(10KPa : Accuracy0.5%)
Power-up response time	≤100ms(riseto90%FS)
Frequencyofsampling	10kHZ
Lifelength	≥10 <sup>6</sup> pressurecycle
Overload pressure	≤1.5times
Medium temperature	-20°C~80°C
Storage temperature	-20°C~120°C
EMC	GB/T17626.2: Electrostatic discharge immunity 2KV; GB/T17626.4: Electrical fast transient/burst immunity 2KV
Insulationresistance	200M /250VDC

### BPM-TT advantages

<p>Reduce the difficulty of production</p> <p>The production process has been optimized and the production steps have been reduced</p>	<p>Reduce labor costs</p> <p>Produce the same number of transmitters within the same period of time, reducing the number of production personnel by three quarters</p>	<p>The production area was reduced</p> <p>All assembly work can be completed with just one workbench</p>
<p>Improve production efficiency</p> <p>It only takes 30 seconds to produce a transmitter, increasing efficiency by 8 times</p>	<p>The product quality has been improved</p> <p>After temperature compensation in the full temperature range of -10 to 70°C, the full-range accuracy/temperature drift can reach 0.25%</p>	<p>Enhance market competitiveness</p> <p>The circuit is easy to match with 0.25 % precision, with low cost, good product and large production capacity</p>

## Selection

project	parameter	code	Code description
	model	BPM-TT	Digital pressure sensors
Sensitive element	break		The following are the specific specifications
	Pressure type	G	gage pressure
		S	Seal the pre-ssure
	Isolation diaphragm material	S	316L stainless steel
		T	Ta
		H	Ha C
	Isolate the tank from the liquid	S	silicone oil
		F	fluorocarbon oil
		O	plant oil
	Sealing method	F	Fully welded seal
Signal output mode	A	4-20mA	

## Product shape structure and wiring definition

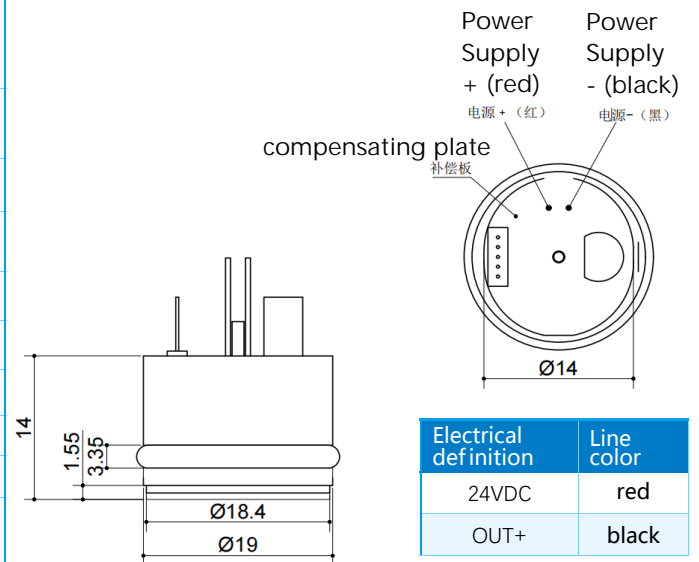

## Comparison of selection schemes

### 1. Traditional solutions

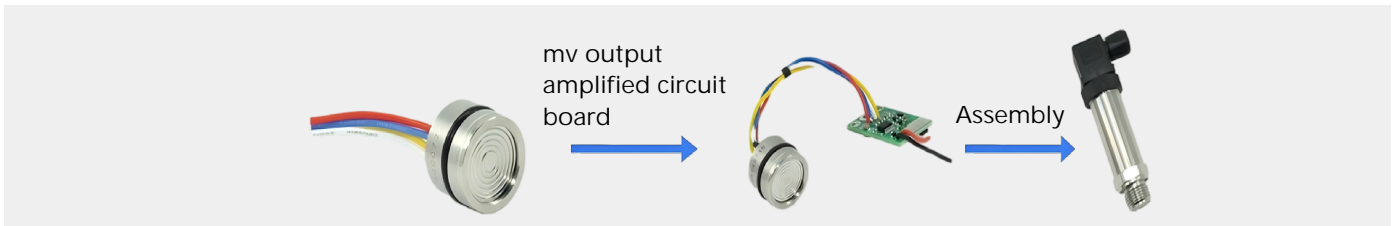

### 2. BPM-TT scheme

