

JY INTELLIGENT SENSOR SERIES

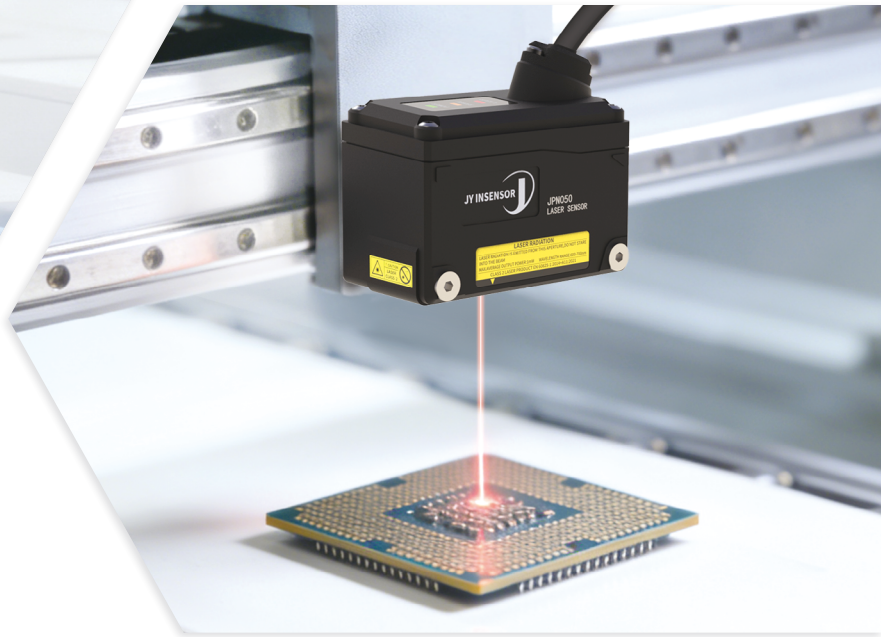

Company Overview

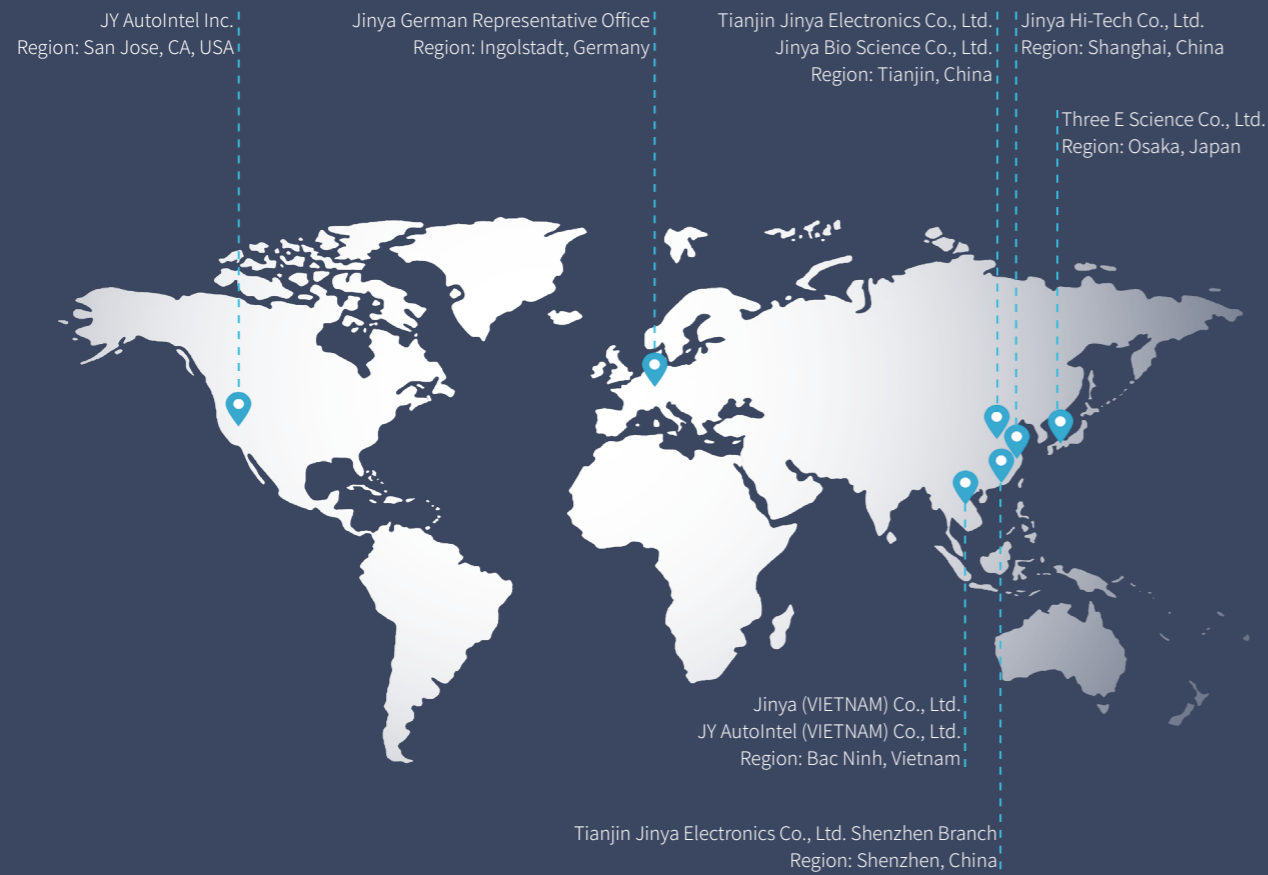

Jinya Electronics is a premier global provider of high-precision sensing technology. We combine decades of Japanese engineering heritage with a modern, borderless innovation network to deliver robust solutions for extremely demanding industrial environments.

Through our European Representative Office in Ingolstadt, Germany, we bridge the gap between global technical expertise and localized customer needs, offering dedicated support and rapid-response consulting for our EU partners.

Company Founded

1996

Intellectual Property

170+

Global Employees

900+

Company Overview

We have built a resilient ecosystem ensuring technical leadership and global delivery reliability:

- **Engineering & Design:** Technical standards anchored in our Japanese headquarters, where core IP and high-precision manufacturing are perfected.
- **Global Innovation:** U.S. R&D hub integrating AI and IoT into established engineering frameworks.
- **Diversified Manufacturing:** Advanced production in Japan, China, and Vietnam under a unified Japanese Quality Management System, ensuring consistent excellence.
- **Regional Expertise:** Ingolstadt office serving as the primary touchpoint for German and European clients with on-site technical coordination.

Why Partner With Us?

- **Proven Reliability:** Products engineered to the highest standards of precision and durability.
- **Global Innovation, Local Service:** Cutting-edge technology delivered through German-based support.
- **Resilient Supply Chain:** Multi-base production (Japan, China, Vietnam) to mitigate logistics risks and ensure stable supply.



— Osaka, Japan —



— Ingolstadt, Germany —



— Tianjin, China —



— Bac Ninh, Vietnam —

R&D Capabilities

Jinya R&D Center features a complete team of senior engineers in optics, mechanics, electronic circuits, and software algorithms, supporting full-cycle development. Our standardized process integrates requirements analysis, concept design, detailed development, prototype fabrication, testing & validation, and mass production handover under strict quality and timeline controls — ensuring efficient delivery of leading-edge, reliable solutions.

R&D Capabilities



JP Series

Laser Displacement Sensor

JPK Series Page 9

Measuring range 14-16 mm
 Repeatability up to 10 nm
 Linearity < $\pm 0.05\%$ MR



JPN&JPS Series Page 11

Measuring range 15-250 mm
 Repeatability up to 0.5 μm
 Linearity < $\pm 0.08\%$ MR



JPD Series Page 15

Measuring range 35-250 mm
 Repeatability up to 4 μm
 Linearity < $\pm 0.1\%$ MR



JPZ Series Page 18

Measuring range 25-340 mm
 Repeatability up to 4 μm
 Linearity < $\pm 0.1\%$ MR



Page 22 JPF Series
 JPF1000, JPF-EP, JPF-ECA
 Laser Displacement Controller & Communication Modules

3D Laser Profiler

JW Series

Page 27 JWB Series
 Z-axis measurement range 5.2-285 mm
 Repeatability up to 0.2 μm



Page 33 JWK Series
 Z-axis measurement range 10.75-254 mm
 Repeatability up to 0.36 μm



3D Snapshot Sensor

JSL Series

Page 39 JSL-Nano
 Measuring range 300-600 mm
 Linearity 0.1% of F.S.



JP Series Laser Displacement Sensor

JPK Laser Displacement Sensor Ultra-High Precision & Speed



Product Overview

The JPK Series is a non-contact, ultra-high-speed, ultra-high-precision laser displacement sensor. The flagship JPK002T offers a 15 mm reference distance and 10 nm repeatability, designed for high-demand inspections under stable conditions — providing core thickness and flatness measurement solutions for precision electronics, photovoltaics, and high-precision machining.

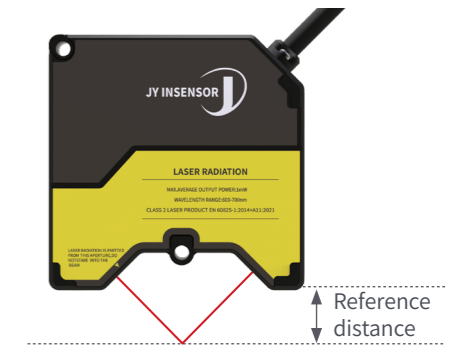

Technical Advantage

- Ultra-High-Speed Scanning**
Meets the demands of high-speed inline inspection
- Ultra-High Precision**
10 nm repeatability
Faithfully captures target detail
- Non-Contact Measurement**
Non-contact, no target damage
Ideal for precision inspection
- Material Versatility**
Unaffected by color or gloss
Stable measurement

Application Scenarios



Runout Measurement
Precision machining & disc runout measurement

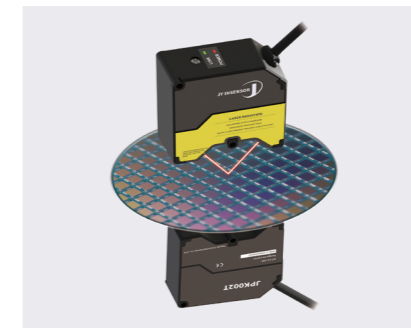

Thickness Measurement
Photovoltaic wafer measurement
Li-ion battery electrode measurement



Warpage & Flatness
Glass panel warpage, flatness & thickness measurement



Product Appearance



Performance Specifications

Model	JPK002T	
Reference Distance	15 mm	
Measuring Range	14-16 mm	
Repeatability	10 nm	
Linearity	< ±0.05 % MR	
Voltage Range	11-30 VDC	
External Input	Data mode, laser mode, zero reset, etc.	
Communication Interface	100BASE-TX	
Measuring Rate	Up to 100 kHz (with ROI enabled)	
Laser	Wavelength	Red laser (658 nm)
	Class	Class2 EN:60825-1:2014+A11:2021
Temperature Range	Storage	-20 ~ +70 ° C (No condensation)
	Work	0 ~ +50 ° C (No condensation)
Weight	Approx. 232 g	
Display	LED indicator × 2	
Protection Class	IP67	

Pin Arrangement

Aviation connector pin arrangement	Pin	Color	Function
<p>M12 Connector 8-pin, A-Code</p>	1	Pink	Input (MF) / RS485+
	2	Black	0V
	3	Red	+Ub
	4	White	TxD-
	5	Blue	RxD+
	6	Green	TxD+
	7	Yellow	Input (MF) / RS485-
	8	Brown	RxD-

Dimensions Diagram

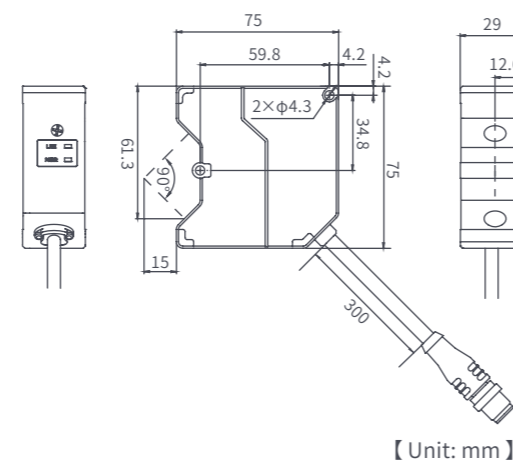

JPN & JPS Laser Displacement Sensor

High Precision
Multi-Scenario Adaptability



Product Overview

The JPN/JPS series targets high-precision, medium-to-high frequency applications. Reference distances from 20–150 mm, measurement range 15–250 mm, with sub-micron to micron accuracy. Compact, IP67-rated, and available standalone or with an amplifier for expanded functionality, perfectly suited for industrial applications with demanding requirements on measurement range and stability.

Technical Advantage

<p>High Precision Repeatability up to 0.5 μm linearity <±0.08% MR</p>	<p>High Frequency Response Up to 5 kHz measurement frequency</p>	<p>Compact Design Compact size, enabling easy installation in confined spaces</p>	<p>IP67 Protection Robust and durable for harsh environments</p>
---	---	--	---

Device Functions

Focused Spot:
Featuring JY INSENSOR's proprietary optical system, the minimum spot diameter is as small as 65 μm, ensuring stable and reliable measurement on smooth surfaces and small workpieces.

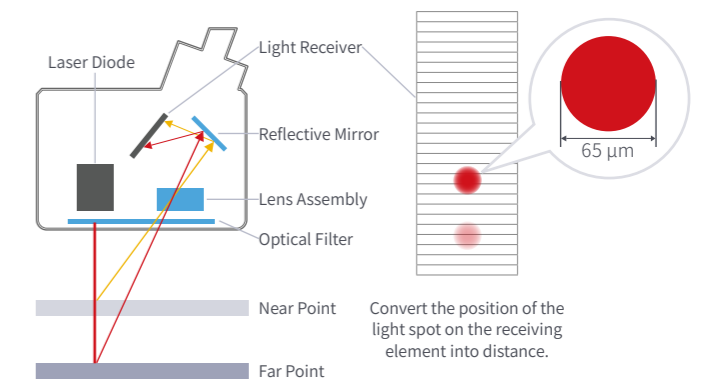

SCAN Function:
Designed for stable measurement across a wide variety of materials, the built-in SCAN function uses JY INSENSOR's self-developed digital circuitry to deliver an ultra-wide dynamic range of up to 3,000,000×.

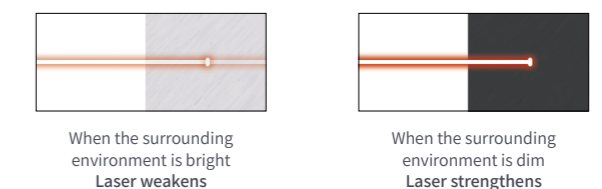

Smart Diagnostics

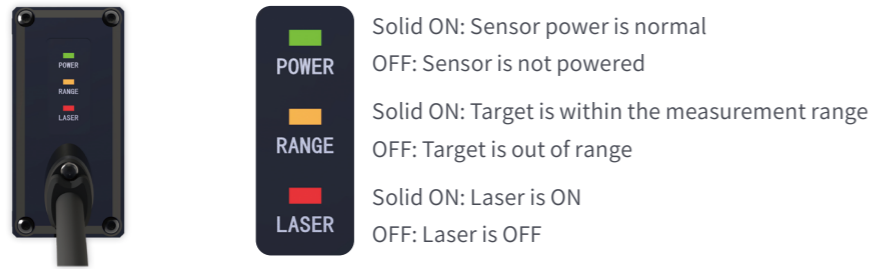

Equipped with red, green, and yellow LED indicators, the sensor provides real-time status feedback for easy on-site setup, debugging, and maintenance.

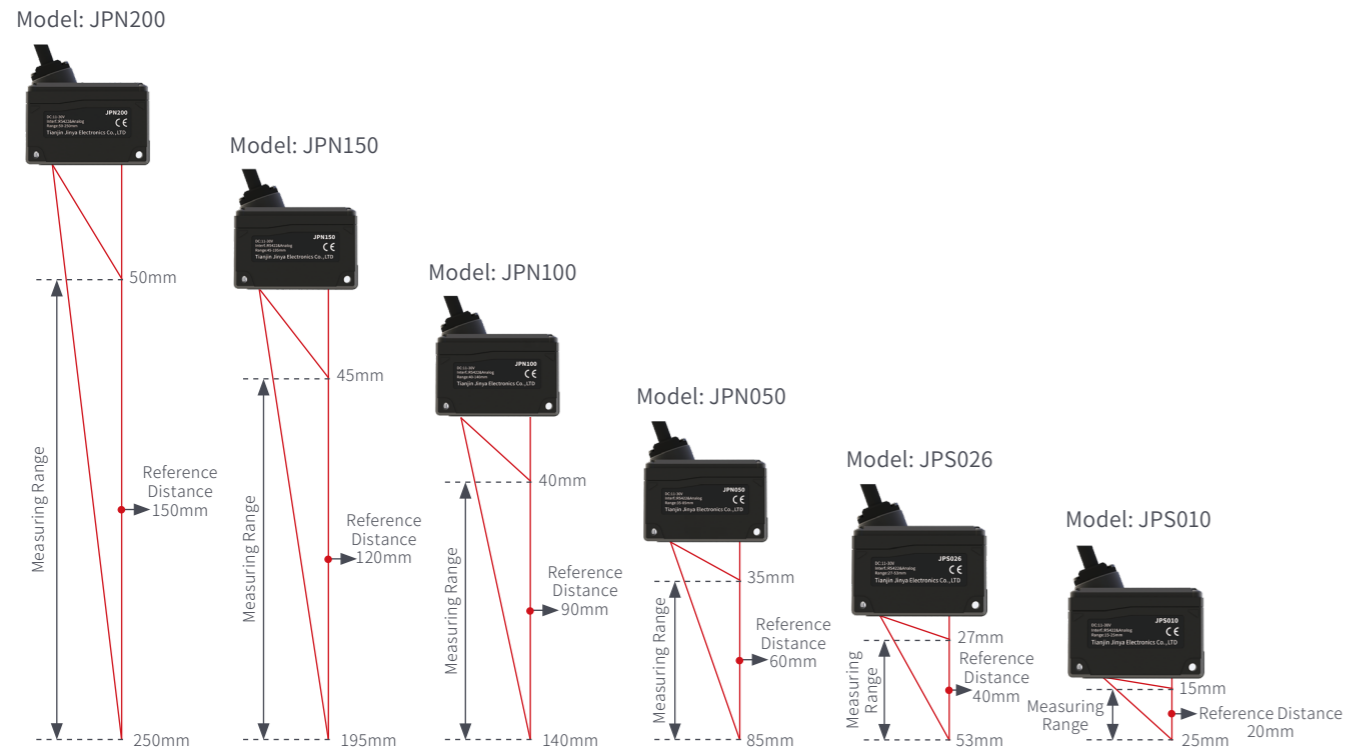

Wide Measuring Range: The long-range model JPN200 offers a measuring range of 150±100 mm — even when switching between different target objects, no adjustment to the sensor mounting height is required.

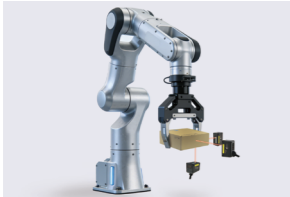
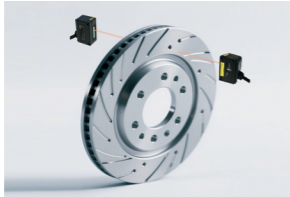
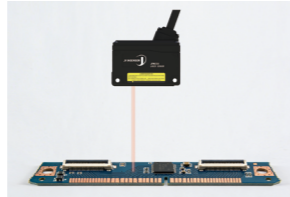

Application Scenarios

			
Height Measurement Robotic arm positioning control Dispensing machine nozzle height control	Thickness Measurement Dual-sensor Disc Thickness Measurement, Metal pressing thickness monitoring	Warpage & Flatness PCB warpage inspection Crankshaft end-face runout inspection	Seam Inspection & Counting Thin material counting on conveyor belts Battery heat sink inspection

Performance Specifications

Model	JPS010	JPS026	JPN050	JPN100	JPN150	JPN200
Reference Distance	20 mm	40 mm	60 mm	90 mm	120 mm	150 mm
Measuring Range	15-25 mm	27-53 mm	35-85 mm	40-140 mm	45-195 mm	50-250 mm
Repeatability ¹	0.5 μm	1 μm	2 μm	4 μm	6 μm	8 μm
Linearity ^{2,3}	< ±0.08 % MR					
Voltage Range	11-30 VDC					
External Input	Data mode, laser mode, zero reset, etc.					
Analog Output	Current: 4-20 mA, Load impedance: 300 Ω or less					
Switch Output	Open collector output (NPN/PNP switchable)					
Communication Interface	RS422					
Power Consumption	< 2 W (24 V)					
Measuring Rate	MAX: 5 kHz					
Laser ⁴	Red laser (658 nm) Laser class: Class2 EN:60825-1:2014+A11:2021					
Protection Class	IP67					
Temperature Range	Storage: -20 ~ +70 °C (No condensation) Work: 0 ~ +50 °C (No condensation)					
Shock Resistance	15 g / 6 ms, 3 axes, 1000 times each in X, Y, and Z axes					
Vibration Resistance	20g/20...500 Hz, 10 cycles each in 2 directions along X, Y, and Z axes					
Weight	Approx. 198 g			Approx. 171 g		
Display	LED indicator × 3					
Material	Housing: Zinc alloy					
Linking Method	300 mm cable with M12 Connector					

¹ Measured at reference distance, sampling period 10 ms, average of 128 times, standard diffuse reflective target (white diffuse object).
² Is the data for measuring standard diffuse objects (white diffuse objects).
³ FS for each model is as follows: JPS010: 10 mm, JPS026: 26 mm, JPN050: 50 mm, JPN100: 100 mm, JPN150: 150 mm, JPN200: 200 mm.
⁴ The FDA's (CDRH) laser classification is based on IEC60825 - 1 and is implemented in accordance with the requirements of Laser Notice No.50.

Pin Arrangement

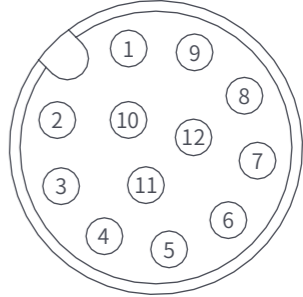
Pin	Color	Function	Aviation connector pin arrangement
1	White	INPUT	
2	Brown	OUTPUT	
3	Green	RS422Rx+	
4	Yellow	RS422Rx-	
5	Gray	RS422Tx+	
6	Blue	RS422Tx-	
7	Red	+Ub	
11	Blue/Red	4-20 mA	
12	Black	0V	

Product Appearance

The full JPN and JPS series laser displacement sensors feature a unified, standardized design that balances industrial installation compatibility with structural consistency.



Circuit Diagram

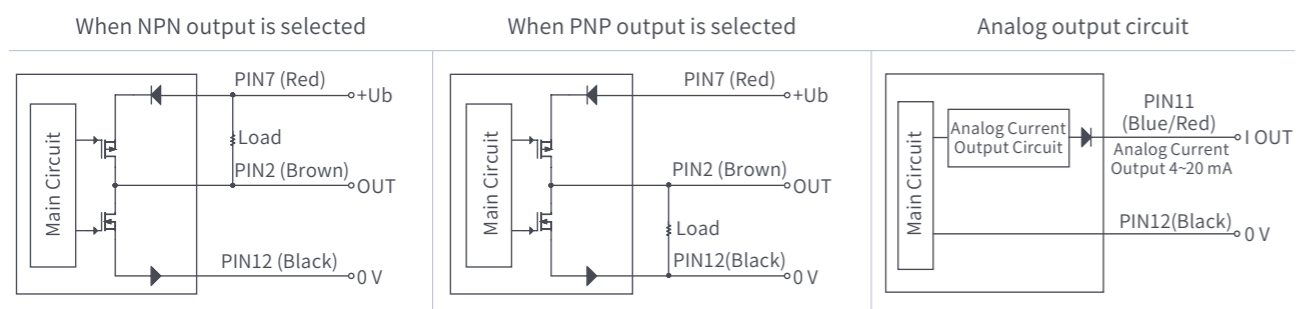

Dimensions Diagram

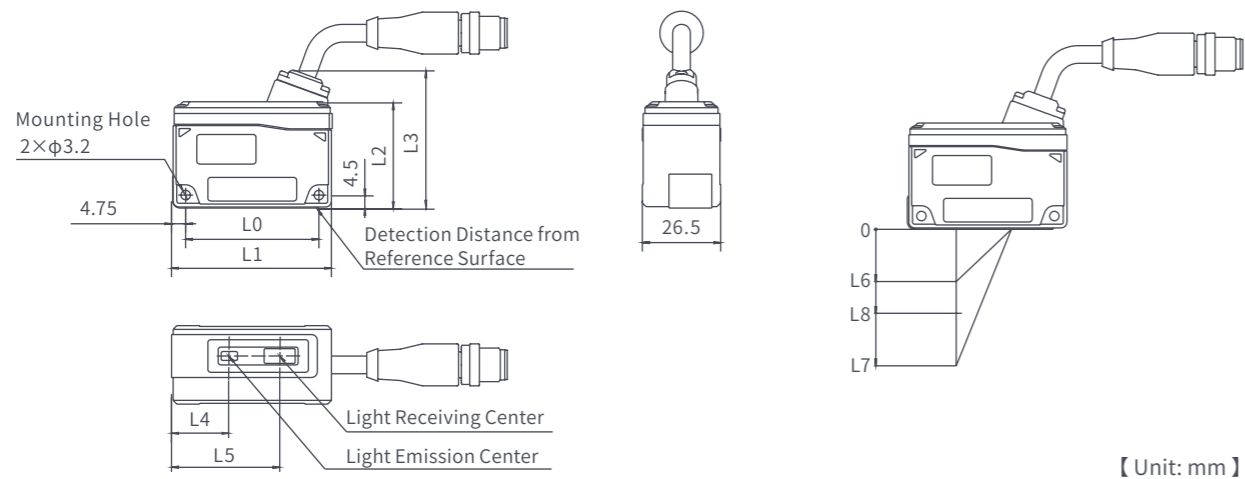

Model	L0	L1	L2	L3	L4	L5	L6	L7	L8
JPS010	50	59	40	50	18.8	33.3	15	25	20
JPS026	50	59	40	50	20.8	36	27	53	40
JPN050	45	54	36	46.3	19.3	35.3	35	85	60
JPN100	45	54	36	46.3	19.8	35.3	40	140	90
JPN150	45	54	36	46.3	20.3	35.7	45	195	120
JPN200	45	54	36	46.3	18.8	37.9	50	250	150

JPD Laser Displacement Sensor

Mid-Precision

Mid-Frequency Response



Product Overview

The JPD Series is a cost-effective laser displacement sensor designed for mid-precision, mid-frequency applications. Covering a measuring range of 35–250 mm with micron-level accuracy, it integrates display and control functions and supports multiple output types — flexibly adapting to complex, multi-function industrial environments to meet all standard measurement needs.

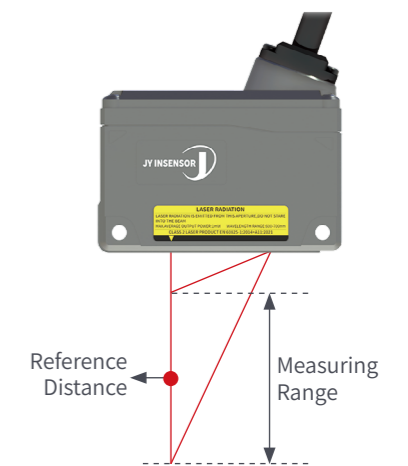

Technical Advantage

- Strong Anti-Interference**
Adapts to complex industrial conditions
Long-lasting operation
- High-Precision Measurement**
Repeatability up to 4 μm
Linearity $\pm 0.1\%$ MR
- Compact Design**
Compact size for easy installation in confined spaces
- Multiple Output Compatibility**
Supports multiple output types
RS485, analog 4–20 mA

Application Scenarios

Height Measurement	Thickness Measurement	Flatness Measurement	Seam Detection & Counting
Dispenser nozzle height control Aluminum wheel hub height positioning	Metal pressing process thickness monitoring Brake disc thickness measurement (dual-sensor)	Engine block flatness inspection Cylinder head sealing surface measurement	Li-ion battery heat sink inspection Conveyor belt sheet counting

Performance Specifications

Model	JPD050	JPD050-D	JPD100	JPD100-D	JPD150	JPD150-D	JPD200	JPD200-D
Reference Distance	60 mm	60 mm	90 mm	90 mm	120 mm	120 mm	150 mm	150 mm
Measuring Range	35-85 mm	35-85 mm	40-140 mm	40-140 mm	45-195 mm	45-195 mm	50-250 mm	50-250 mm
Repeatability ^{*1}	4 μm	4 μm	6 μm	6 μm	8 μm	8 μm	10 μm	10 μm
Analog Output	4-20 mA Load impedance: 300 Ω or less	—	4-20 mA Load impedance: 300 Ω or less	—	4-20 mA Load impedance: 300 Ω or less	—	4-20 mA Load impedance: 300 Ω or less	—
Linearity ^{*2,3}	< ±0.1% MR							
Voltage Range	11-30 VDC							
External Input	Data mode, laser mode, zero reset, etc.							
Switch Output	Open collector output (NPN / PNP switchable)							
Communication Interface	RS485							
Measuring Rate	MAX: 2 kHz							
Laser ^{*4}	Red laser (658 nm)							
Protection Class	IP67							
Temperature Range	Storage	-20 ~ +70 ° C (No condensation)						
	Work	0 ~ +50 ° C (No condensation)						
Shock Resistance	15 g / 6 ms, 3 axes, 1000 times each in X, Y, and Z axes							
Vibration Resistance	10-55 Hz, double amplitude 1.5 mm, 2 hours each in X, Y, and Z directions							
Weight	Approx. 108 g							
Display	LED indicator ×3							
Material	Housing: Aluminum alloy							
Linking Method	300 mm cable with M12 Connector							

*1 Measured at reference distance, sampling period 10 ms, average of 128 times, standard diffuse reflective target (white diffuse object).
 *2 Data for measuring standard diffuse reflective target (white diffuse object).
 *3 MR per model: JPD050 / JPD050-D: 50 mm; JPD100 / JPD100-D: 100 mm; JPD150 / JPD150-D: 150 mm; JPD200 / JPD200-D: 200 mm.
 *4 FDA (CDRH) laser classification is based on IEC60825-1 and implemented in accordance with the requirements of Laser Notice No. 50.

Pin Arrangement

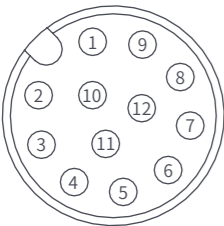
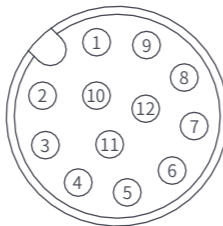
JPD: Aviation connector pin arrangement	Pin	Color	Function	JPD-D: Aviation connector pin arrangement	Pin	Color	Function
	1	White	INPUT		1	White	INPUT
	2	Brown	OUTPUT		2	Brown	OUTPUT
	3	Green	RS485A		3	Green	RS485A
	4	Yellow	RS485B		4	Yellow	RS485B
	7	Red	+Ub		7	Red	+Ub
	11	Blue/Red	4-20 mA		11	Blue/Red	4-20 mA
	12	Black	0V		12	Black	0V

Product Appearance

The full JPD and JPD-D series laser displacement sensors feature a unified, standardized design that balances industrial installation compatibility with structural consistency.



Circuit Diagram

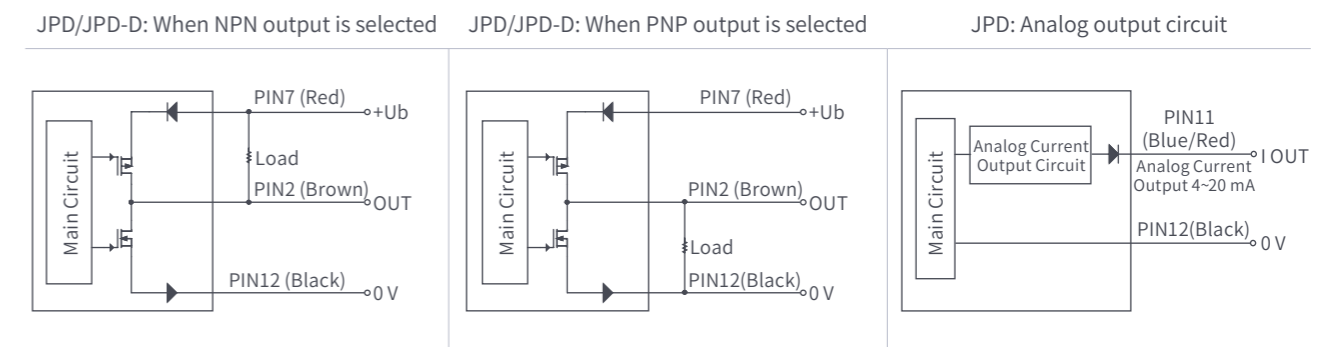

Dimensions Diagram

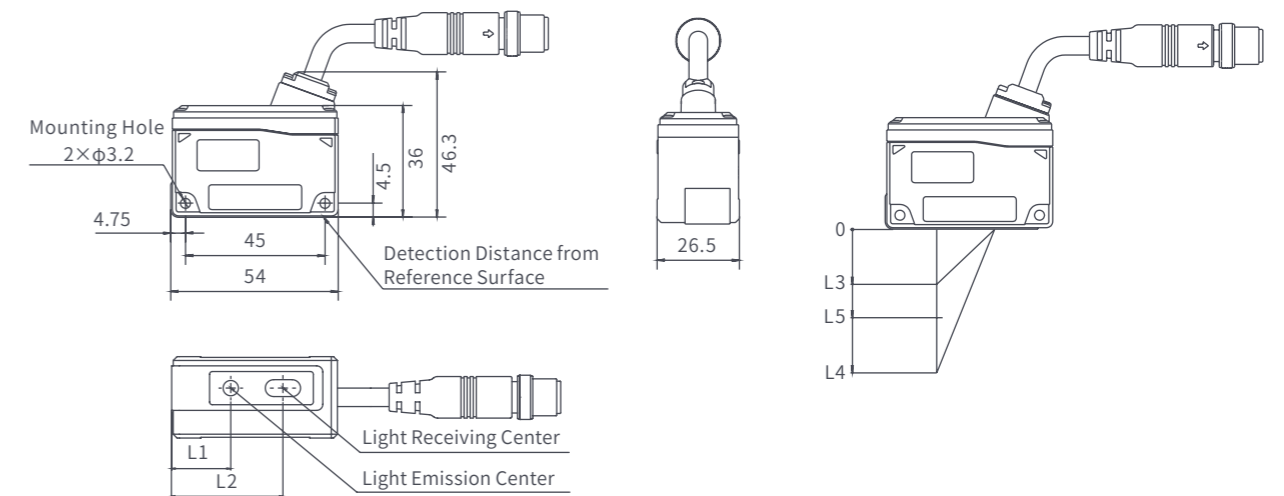

【Unit: mm】

Model	L1	L2	L3	L4	L5
JPD050/JPD050-D	19.3	35.3	35	85	60
JPD100/JPD100-D	19.8	35.3	40	140	90
JPD150/JPD150-D	20.3	35.7	45	195	120
JPD200/JPD200-D	18.8	37.9	50	250	150

JPZ Laser Displacement Sensor

Multi-scenario compatible

Easy to operate



Product Overview

The JPZ Series is a cost-effective, highly adaptable laser displacement sensor developed for low-precision, mid-frequency applications. Covering a measuring range of 25–340 mm with tens-of-microns accuracy, it integrates display and control functions for ease of use — ideal for cost-sensitive, large-scale industrial deployments requiring basic measurement capabilities.

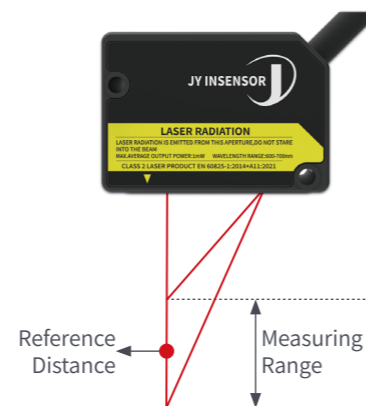

Technical Advantage



Wide Measuring Range
Covers 25–340 mm
Meets basic ranging requirements



Easy Operation
Integrated display and control functions
Ready to use out of the box



Industrial Adaptability
Adapts to all standard industrial
Basic measurement needs



Cost-Effective
Effective cost control
Suitable for large-scale deployment

Application Scenarios

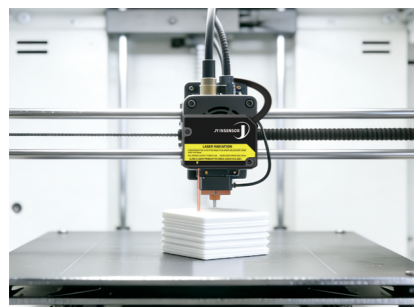

Height Measurement

3D print workpiece profile monitoring
PCB component mounting height monitoring



Thickness Measurement

Woodworking panel thickness measurement
Adhesive tape roll film thickness inspection



Dimension Measurement

Assembly toy dimension measurement
Metal workpiece width inspection

Smart Diagnostics

Red and green LED indicators provide real-time status feedback, enabling easy on-site debugging and maintenance.



LASER ■ Solid on: Laser is active
Off: Laser is inactive

OUT ■ Solid on: Output channel is active
Off: Output channel is inactive

Component Description

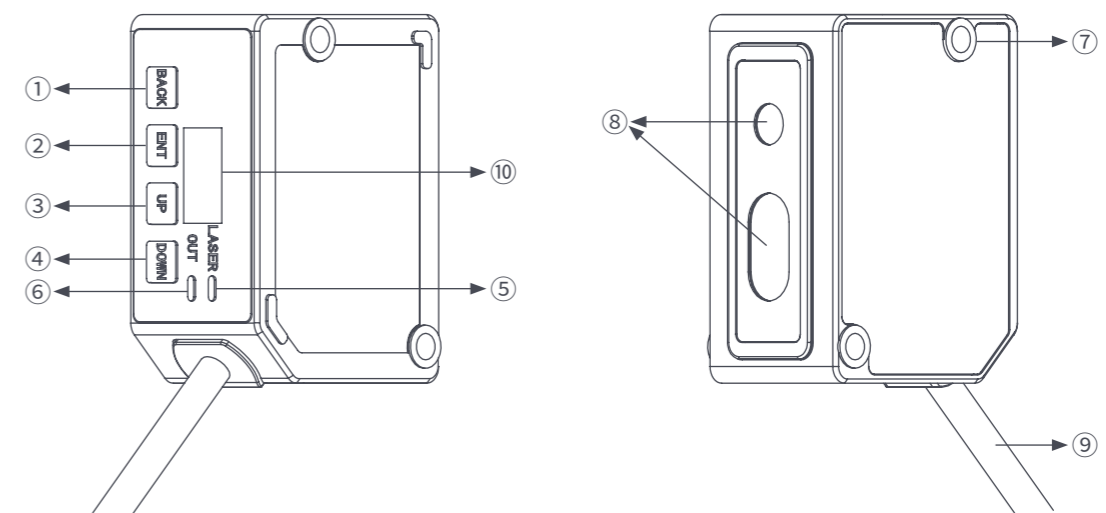

Item	Description
① BACK Key	Back
② ENT Key	Confirm
③ UP Key	Scroll up
④ DOWN Key	Scroll down
⑤ Laser Indicator - Red	Solid on when laser is active
⑥ Output Indicator - Green	Solid on when output channel is active
⑦ Mounting Holes	Used to mount and secure the sensor body
⑧ Laser Receiver & Emitter	Laser receiver port and laser emitter port
⑨ External Cable	Cable connecting to the sensor body
⑩ Display Area	Screen display area

Performance Specifications

Model	JPZ010	JPZ020	JPZ040	JPZ120	JPZ300
Reference Distance	30 mm	45 mm	50 mm	95 mm	190 mm
Measuring Range	25-35 mm	35-55 mm	30-70 mm	35-155 mm	40-340 mm
Repeatability ^{*1}	4 μm	8 μm	15 μm	45 μm	100 μm
Linearity ^{*2,3}	< ±0.1 % MR				
Voltage Range	11-30 VDC				
External Input	Data mode, laser mode, zero reset, etc.				
Analog Output	Current: 4~20 mA, Load impedance: 300 Ω or less				
Switch Output	NPN open collector output				
Communication	RS485				
Power Consumption	< 2 W (24 V)				
Measuring Rate	MAX: 2 kHz				
Laser ^{*4}	Red laser (658 nm) Laser class: Class2 EN:60825-1:2014+A11:2021				
Protection Class	IP65				
Temperature Range	Storage	-20 ~ +70 °C (No condensation)			
	Work	0 ~ +50 °C (No condensation)			
Shock Resistance	15 g / 6 ms, 3 axes, 1000 times each in X, Y, and Z axes				
Vibration Resistance	20g / 20...500 Hz, 3 axes, 2 directions, 10 cycles each				
Weight	Approx. 131 g				
Display	OLED display; LED indicator ×2				
Material	Housing: Aluminum alloy				
Linking Method	Loose wires				

*1 Measured at reference distance, sampling period 10 ms, average of 128 times, standard diffuse reflective target (white diffuse object).
 *2 Data for measuring standard diffuse reflective target (white diffuse object).
 *3 MR per model: JPZ010: 10 mm; JPZ020: 20 mm; JPZ040: 50 mm; JPZ120: 120 mm; JPZ300: 300 mm.
 *4 FDA (CDRH) laser classification is based on IEC60825-1 and implemented in accordance with the requirements of Laser Notice No. 50.

Circuit Diagram

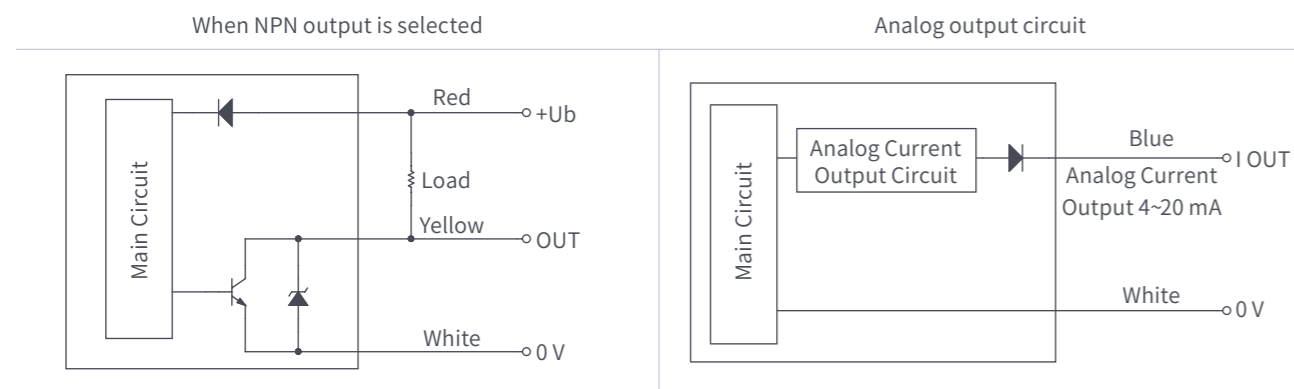

Product Appearance

The full JPZ Series laser displacement sensors feature a unified, standardized design that balances industrial installation compatibility with structural consistency.



Pin Arrangement

Pin	Color	Function
1	Gray	RS485B
2	Green	RS485A
3	Brown	INPUT
4	Yellow	NPN_OUT
5	Blue	IOUT
6	White	0V
7	Red	+Ub

Dimensions Diagram

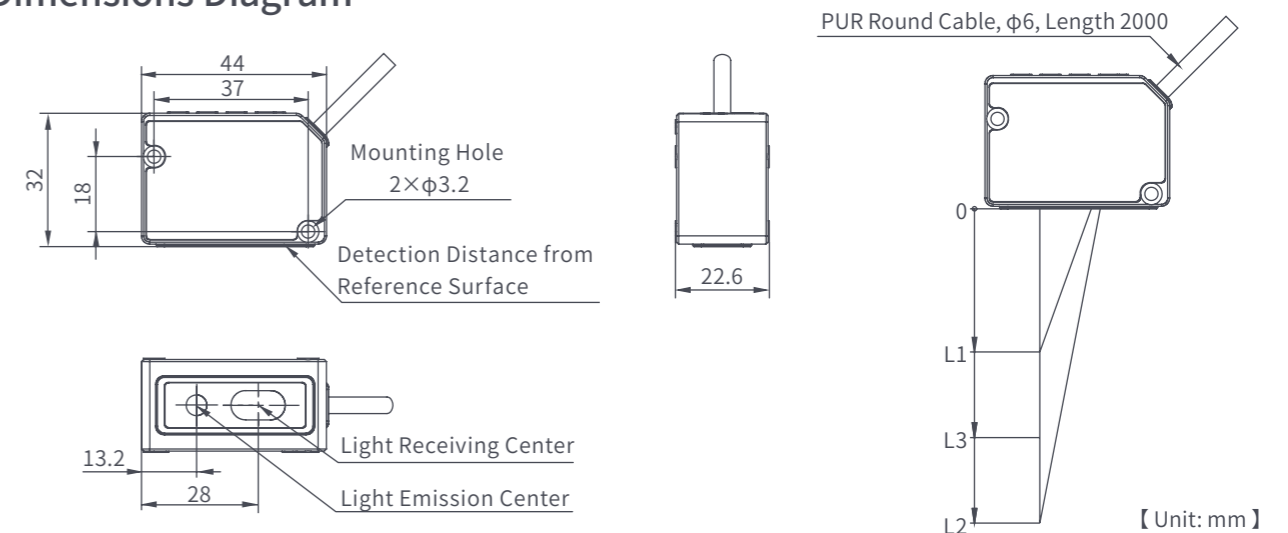

Model	L1	L2	L3
JPZ010	25	35	30
JPZ020	35	55	45
JPZ040	30	70	50
JPZ120	35	155	95
JPZ300	40	340	190

JPF Laser Displacement Sensor Controller Open Field Network Unit



Product Overview

The JPF is a high-precision, intelligent industrial controller purpose-built for laser displacement detection. It supports real-time data acquisition, up to 15-node synchronous measurement, and precise range calculation. Dual analog outputs (4–20 mA / ±10 V) enable direct PLC/DCS integration. Multi-language support, compatible with all precision industrial inspection environments.

Technical Advantage

High-Precision Measurement	Flexible Networking	Intelligent Output	User-Friendly Operation
Real-time displacement sensor data acquisition/processing Supports multi-point synchronous measurement (Max 15 nodes)	Host / Client dual modes CAN Bus communication Distributed measurement system	Dual analog outputs (4–20 mA / ±10 V) Direct connection to PLC/DCS systems Real-time data reporting	128×32 OLED Display Simple 3-button operation Multi-language support (CN / JP / EN)

Application Scenarios

<p>Industrial Production Lines Real-time flatness detection / Product thickness monitoring / Automated quality control</p>	<p>Precision Manufacturing Multi-point displacement synchronous monitoring / Product size detection / Assembly accuracy control</p>
<p>Automation Equipment Position feedback control / Stroke monitoring / Equipment status monitoring</p>	<p>Quality Inspection Online inspection and sorting / Data recording and traceability / Real-time alarm prompts</p>

Circuit Diagram

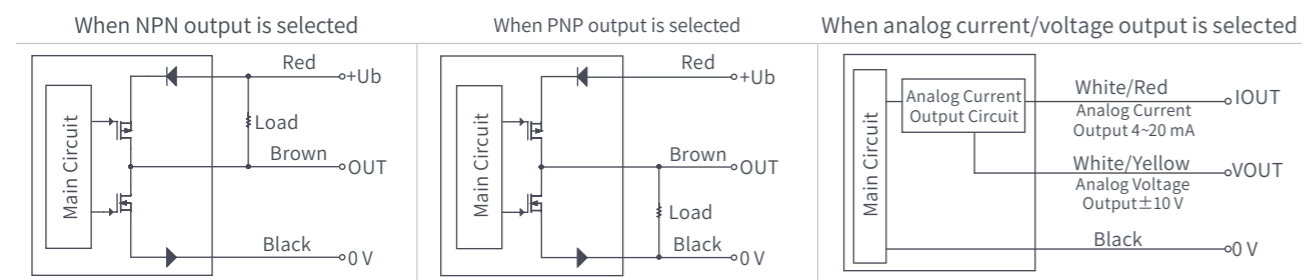

Product Appearance & Dimensions

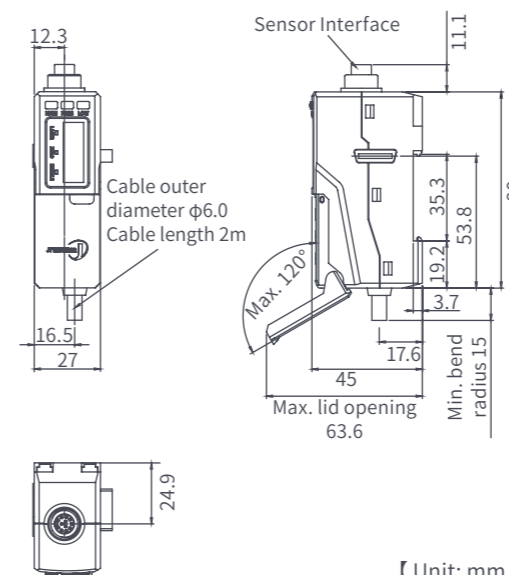

【 Unit: mm 】

Device Functions

Function Module	Description
Real-time Measurement	Automatically acquires sensor data at 5 kHz; supports trigger synchronization mode
Data Processing	Supports Normal / Max / Min / Range (Peak-to-Peak) measurement modes
Filtering Algorithms	Median filtering and Gaussian filtering to effectively reduce data jitter
Threshold Judgment	Upper and lower limits can be set; automatic alarm triggering when limits are exceeded
Parameter Storage	Configuration parameters are saved upon power-off; no need to reset

Performance Specifications

Model	JPF1000
Display	OLED display; LED indicator ×6
Voltage Range	11-30 VDC
External Input	2-channel multi-function pulse input • Multi-unit synchronization • Acquisition start/stop control
Analog Output	Current: 4–20 mA, Load: ≤ 300 Ω; Voltage: -10~10 V, Output impedance: ≤ 100 Ω
Switch Output	2-channel open collector output (NPN / PNP switchable)
Communication	RS-485/RS-422
Protection Class	IP40
Temperature Range	Work: -10°C ~ 50 °C Storage: -20°C ~ 70 °C
Relative Humidity	<85% (No condensation)

Pin Arrangement

Pin	1	2	3	4	5	6	7	8	9	10	11	12	13	14	PE
Color	Black	Red	Orange	White/Orange	Blue	White/Blue	Brown	White/Brown	Gray	White/Gray	Green	Yellow	White/Red	White/Yellow	
Function	0 V	+Ub	INPUT1	OUTPUT1	INPUT2	OUTPUT2	Reserved	Reserved	Reserved	Reserved	RS485A	RS485B	Analog ±10 V	Analog 4-20 mA	Shield

- * Always power off before wiring
- * Verify power polarity to avoid reverse connection
- * Add 120Ω termination resistors at both ends of the RS-485 bus
- * Route analog ground (AGND) and signal ground (GND) separately

Communication Interface

Interface	Function	Baud Rate	Protocol
Debug interface	Host PC communication / debugging	115200bps	RS-485
Sensor interface	Sensor data communication	921600/460800/115200/38400/9600	RS-422

Product Appearance & Dimensions

JPF-EP

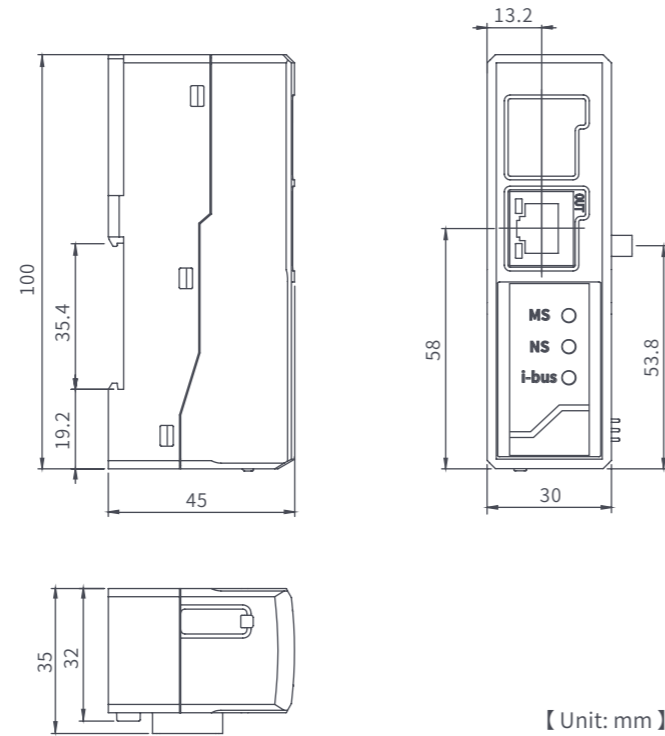

【Unit: mm】

JPF-ECA

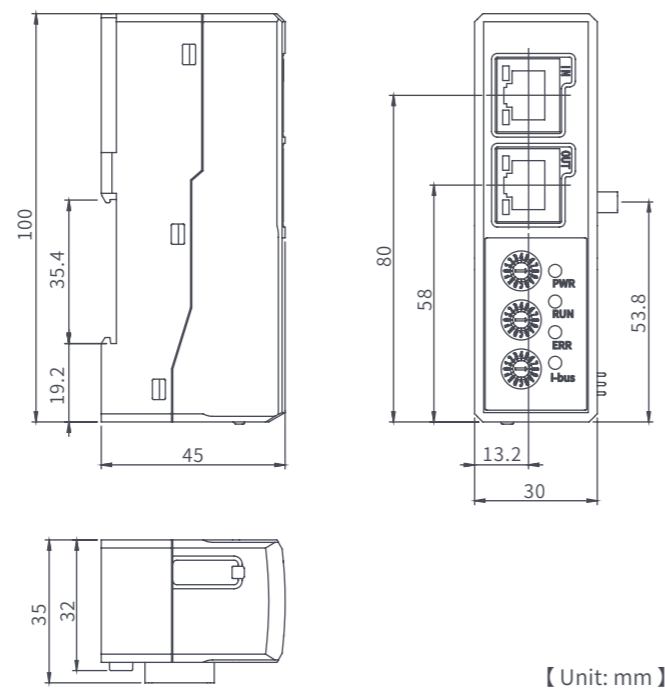

【Unit: mm】

Device Functions

By connecting to field network communication, all data can be processed in a simplified manner — supporting judgment result retrieval, measurement value reading, I/O control, and parameter configuration changes via PLC or computer.

Model	JPF-EP	JPF-ECA
Monitoring	Sensor status can be confirmed on a PLC or computer, enabling easy verification and early detection of issues before anomalies occur.	
Parameter Changes	Settings can be changed via external devices such as a PLC or computer, reducing switchover time.	

Performance Specifications

Model	JPF-EP	JPF-ECA
Display	LED indicator ×4	LED indicator ×4
Voltage Range	11 - 30 VDC	11 - 30 VDC
Communication Interface	100Base-TX	EtherCAT
Protection Class	IP40	IP40
Operating temperature	-10°C ~ 50 °C	-10°C ~ 50 °C
Storage temperature	-20°C ~ 70 °C	-20°C ~ 70 °C
Relative humidity	<85% (No condensation)	<85% (No condensation)

Communication Interface

Model	JPF-EP	JPF-ECA
Appearance		
Communication	EtherNet/IP	EtherCAT/IP
Connectable devices	PC, PLC	PC, PLC

JW Series 3D Laser Profiler

JWB 3D Laser Profiler

High precision
Built for any environment



Product Overview

JWB Series 3D Laser Profiler: Blue laser with 3,200 points/profile output. Built-in high-precision algorithms deliver real-time profile, point cloud, and positioning data. Strong interference resistance and stable performance across a wide range of target materials and complex environments.

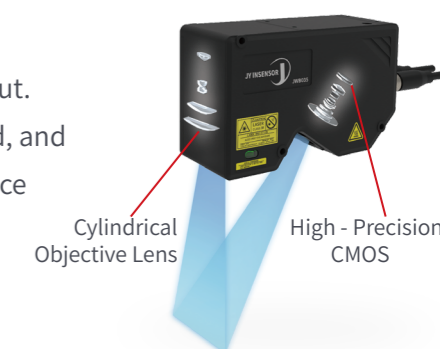

Technical Advantage

- Precision Measurement**
Dedicated algorithm team for complex application needs
- High Precision**
High-res CMOS for micron-level accuracy
- Excellent environmental adaptability**
Optimized optics + Ambient light rejection algorithm
Stable on complex surfaces and varied lighting
- Wide Material Compatibility**
Works on metal, plastic, glass
Regardless of color or gloss

Application Scenarios

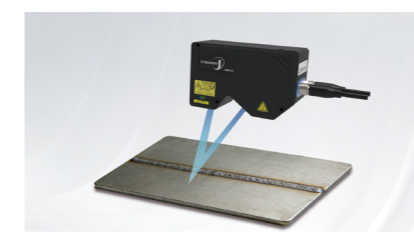

Dimensional Inspection

Post-weld dimensional and defect inspection
Automotive fixture dimensional inspection



Shape Inspection

Measures adhesive bead geometry, dimensions, and solder paste thickness distribution and volume.

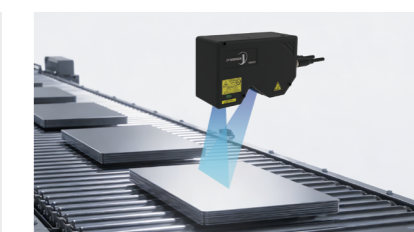

Surface Inspection

Flatness measurement and defect detection on machined metal components

Device Functions

Positioning & Guidance	Precision positioning	Attitude correction						
Shape Inspection	Presence	Orientation	Lifted	Warpage	Gap	Counting		
Dimension Inspection	Height	Depth	Width	Thickness	Step height	Angle	Flatness	
Appearance Inspection	Volume	Burr	Dent	Foreign object	Crack	Defect	Deformation	Surface irregularity



HDR Single Frame:

The high-sensitivity CMOS features single-frame HDR capability. A single shot (exposure) enables stable, high-precision measurement of high-contrast surfaces.

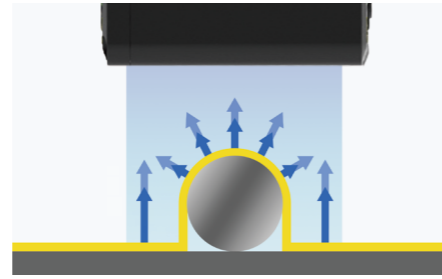

Performance Specifications

Model		JWB3P5Z	JWB7P5	JWB016	JWB035	JWB072	JWB100
Z - axis ^{*1}	Near	5.2 mm	10 mm	21.5 mm	52.5 mm	132 mm	145 mm
	Reference Distance	5.7 mm	12 mm	29.5 mm	73 mm	192 mm	215 mm
	Far	6.2 mm	14 mm	37.5 mm	93.5 mm	252 mm	285 mm
	Measurement Range	1 mm	4 mm	16 mm	41 mm	124 mm	140 mm
	Linearity accuracy ^{*2}	±0.05% of F.S.	±0.04% of F.S.	±0.04% of F.S.	±0.04% of F.S.	±0.04% of F.S.	±0.05% of F.S.
	Repeatability ^{*3}	0.2 μm	0.3 μm	0.4 μm	0.5 μm	2 μm	3 μm
X - axis ^{*4}	Near	3.5 mm	7 mm	14 mm	30 mm	60 mm	77 mm
	Reference Distance	3.6 mm	7.5 mm	16 mm	35 mm	72 mm	100 mm
	Far	3.7 mm	8 mm	18 mm	40 mm	85 mm	123 mm
	Repeatability ^{*3}	0.2 μm	0.3 μm	0.5 μm	1 μm	3 μm	5 μm
Light Source ^{**6}	Type	Blue Semiconductor Laser (405 nm)					
	Laser Class	Class 3R					
Voltage Range		11-30 VDC					
Switch Output		Open collector output (NPN/PNP switchable), N.O./N.C. switchable					
Communication Interface		1000BASE-T					
Encoder		Differential encoder (5 V output: max 150 mA)					
HDR (High dynamic range) ^{*7}		Single frame HDR					
Operating Temperature		0-45° C					
Profile Data Points		3200 points					
Measuring Rate		250 Hz - 16 kHz					
Display		LED indicator × 2					
Material		Housing: Aluminum alloy					
Protection Class ^{*8}		IP67					

*1 Measurement target: standard diffuse object. The average height value measured in the initial set area using the height/position tool is the specified value. Other settings remain default.
 *2 Measurement target: standard diffuse object. The profile data is measured after 64 smoothing processes and 8 averaging steps. Other settings remain default.
 *3 The value is the average of 4096 measurements taken at the reference distance.
 *4 Measurement target: pin gauge. Measure R-surface/edge intersection with height/position tool. Other settings are default.
 *5 Classification according to FDA (CDRH) Laser Notice No. 56, based on IEC60825 - 1 standards.
 *6 Do not directly observe the laser beam using optical devices such as magnifying glasses or telescopes.
 *7 One exposure (shot) is sufficient for stable and high - precision measurements of surfaces with significant contrast differences.
 *8 Values when the sensing head cable or extension cable is connected.

Pin Arrangement

Pin	Color	Function	Power signal connector pin arrangement
1	Brown	INPUTX_A	
2	Blue	Reserved	
3	White	INPUTX_B	
4	Green	INPUT2	
5	Pink	INPUTY_A	
6	Yellow	INPUT1	
7	Black	INPUTY_B	
8	Gray	IOOUT1	
9	Red	INPUTZ_A	
10	Purple	IOOUT2	
11	Red-Blue	INPUTZ_B	
12	Brown/Green	MFL_OUT	
13	Gray/Red	Reserved	
14	White/Gray	0 V	
15	White/Yellow	+Ub	
16	White/Green	0 V	
17	Yellow/Brown	+Ub	
Shell	Shell (Shield)		

Pin	Color	Network connector pin arrangement
1	White/Orange	
2	Orange	
3	White/Green	
4	Green	
5	White/Blue	
6	Blue	
7	White/Brown	
8	Brown	

Product Appearance & Dimensions

JWB3P5Z

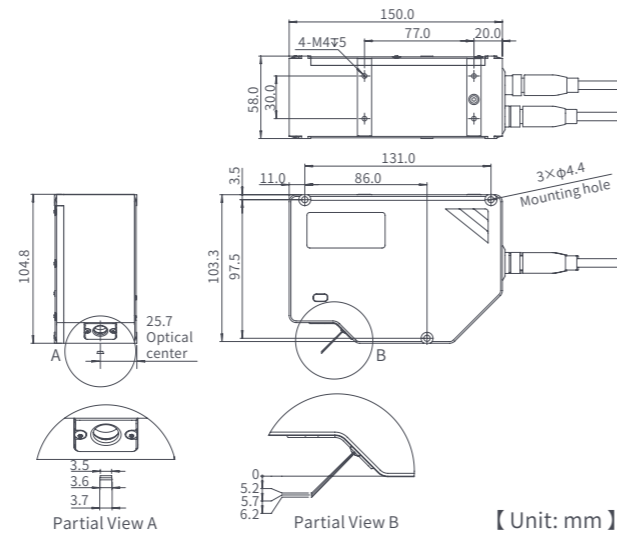

JWB7P5

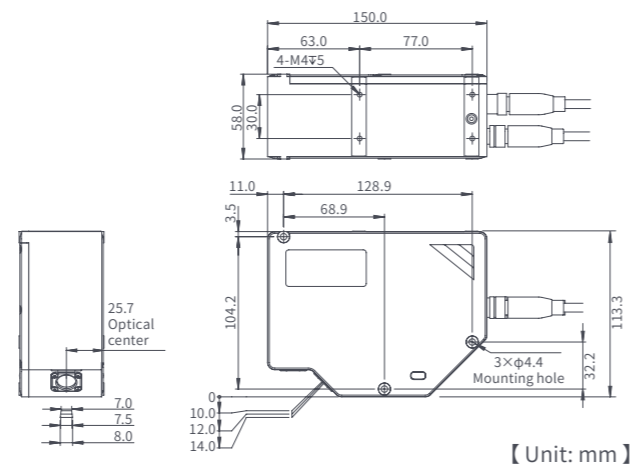

JWB016

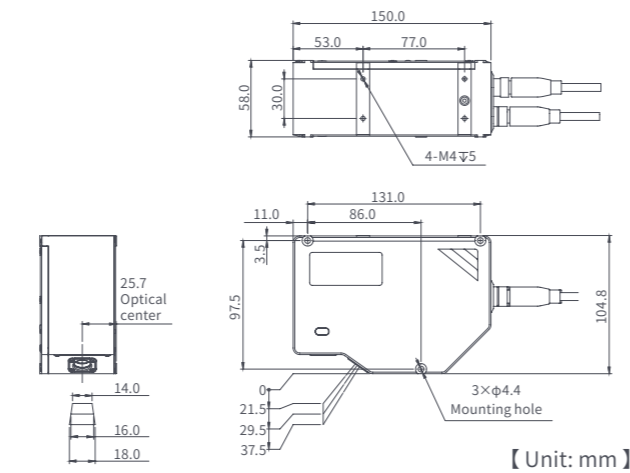

Product Appearance & Dimensions

JWB035

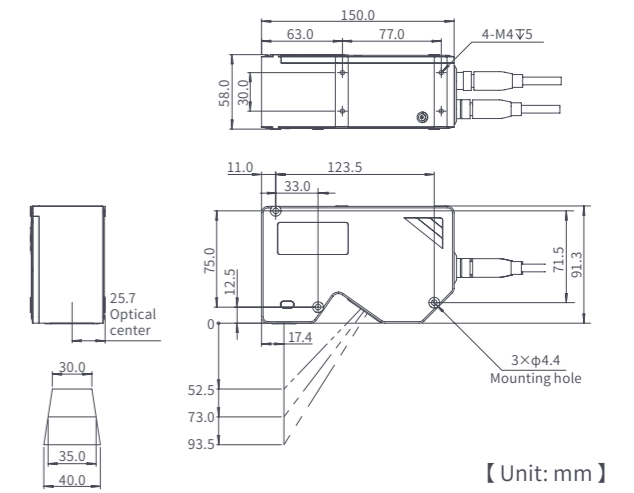

JWB072

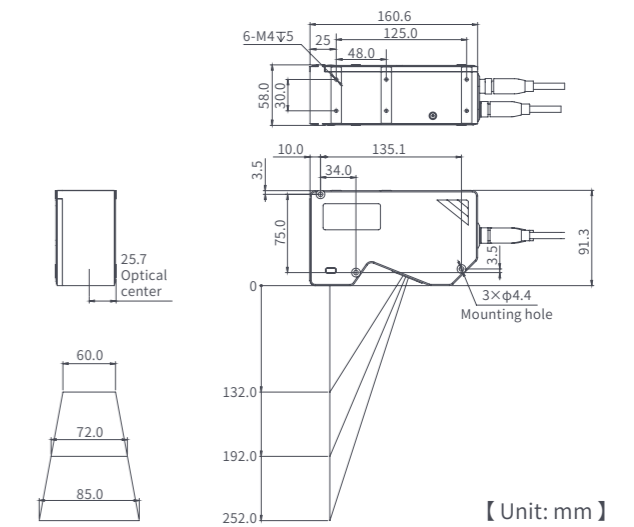

JWB100

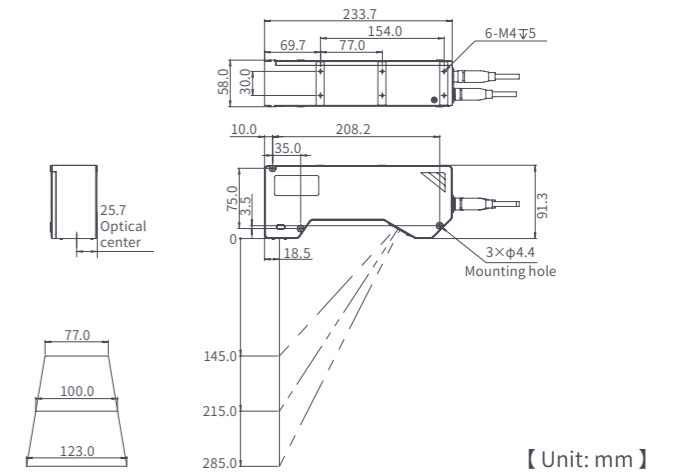

Circuit Diagram

<p>Three differential signal pairs are internally converted to single-ended signals, transmitting encoder phase and revolution data to the processing chip. The differential signals are compatible with RS-422 voltage levels.</p>	
<p>When NPN output mode is selected, connect the load according to the reference circuit.</p>	
<p>When PNP output mode is selected, connect the load according to the reference circuit.</p>	
<p>By controlling the optocoupler emitter, the circuit connected to the receiver can be controlled in an isolated manner.</p>	
<p>The multi-function input signal polarity (NPN/PNP) is configured via software, used to detect external NPN/PNP input signals.</p>	

JWK 3D Laser Profiler Designed for High-Speed Measurement Applications



Product Overview

Compared to the JWB Series, the JWK Series significantly increases measurement speed while maintaining high accuracy. With a maximum measuring rate of 16 kHz and a full-range rate of 1.5 kHz, it is stable and highly adaptable, operating standalone and perfectly suited for high-speed automation applications demanding speed, precision, and stability.

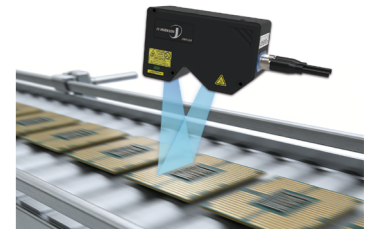

Technical Advantage

- Non-Contact Measurement**
No contact, no damage to target
- Ultra-High-Speed Scanning**
Optimized for high-speed production lines with outstanding efficiency
- Fine Detail Reproduction**
Unaffected by color or surface gloss
- Professional Algorithm Support**
Built-in professional algorithms ensuring measurement accuracy

Application Scenarios



Dimension Inspection
Gap measurement in robot assembly

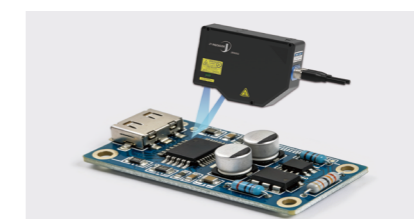

Appearance Inspection
Defect and dimension inspection of capacitors, resistors, and other components



Shape Inspection
Automotive weatherstrip profile inspection

Device Functions

Positioning & Guidance	Precision positioning	Attitude correction					
Shape Inspection	Presence	Orientation	Lifted	Warpage	Gap	Counting	
Dimension Inspection	Height	Depth	Width	Thickness	Step height	Angle	Flatness
Appearance Inspection	Volume	Burr	Dent	Foreign object	Crack	Defect	Deformation Surface irregularity

Performance Specifications

Model	JWK007	JWK015	JWK034	JWK072	JWK094	
Z - axis ^{*1}	Near	10.75 mm	25.5 mm	61 mm	125.5 mm	176 mm
	Reference Distance	12 mm	30 mm	73 mm	163 mm	215 mm
	Far	13.25 mm	34.5 mm	85 mm	200.5 mm	254 mm
	Measurement Range	2.5mm	9 mm	24 mm	75 mm	78 mm
	Linearity accuracy ^{*2}	±0.048% of F.S.	±0.048% of F.S.	±0.048% of F.S.	±0.048% of F.S.	±0.06% of F.S.
X - axis ^{*4}	Near	6.5 mm	14 mm	30 mm	58 mm	80 mm
	Reference Distance	7 mm	15 mm	34 mm	72 mm	94 mm
	Far	7.5 mm	16.5 mm	38 mm	86 mm	106 mm
	Repeatability ^{*3}	0.36 μm	0.6 μm	1.2 μm	3.6 μm	6 μm
Light Source ^{*5*6}	Type	Blue Semiconductor Laser				
	Laser Class	Class 3R				
Voltage Range	11-30 VDC					
Switch Output	Open collector output (NPN/PNP switchable), N.O./N.C. switchable					
Communication Interface	1000BASE-T					
Encoder	Differential encoder (5 V output: max 150 mA)					
HDR (High dynamic range) ^{*7}	Single frame HDR					
Operating Temperature	0 - 45° C					
Profile Data Points	3200 points					
Measuring Rate	1500 Hz - 16 KHz					
Display	LED indicator × 2					
Material	Housing: Aluminum alloy					
Protection Class ^{*8}	IP67					

*1 Measurement target: standard diffuse object. The average height value measured in the initial set area using the height/position tool is the specified value. Other settings remain default.
 *2 Measurement target: standard diffuse object. The profile data is measured after 64 smoothing processes and 8 averaging steps. Other settings remain default.
 *3 The value is the average of 4096 measurements taken at the reference distance.
 *4 Measurement target: pin gauge. Measure R-surface/edge intersection with height/position tool. Other settings are default.
 *5 Classification according to FDA (CDRH) Laser Notice No. 56, based on IEC60825 - 1 standards.
 *6 Do not directly observe the laser beam using optical devices such as magnifying glasses or telescopes.
 *7 One exposure (shot) is sufficient for stable and high - precision measurements of surfaces with significant contrast differences.
 *8 Values when the sensing head cable or extension cable is connected.

Product Appearance & Dimensions

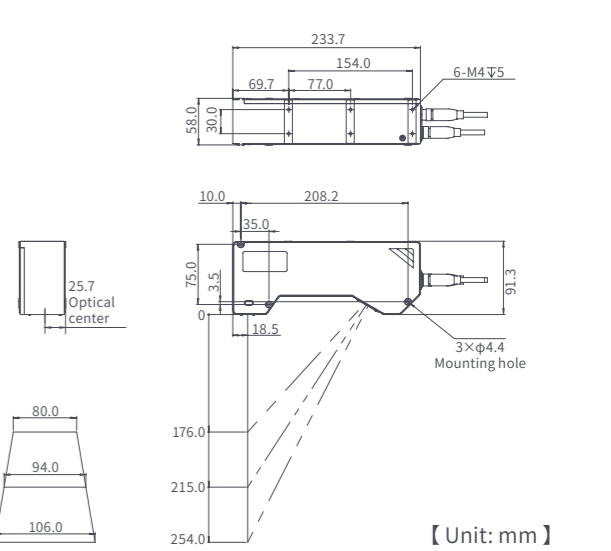
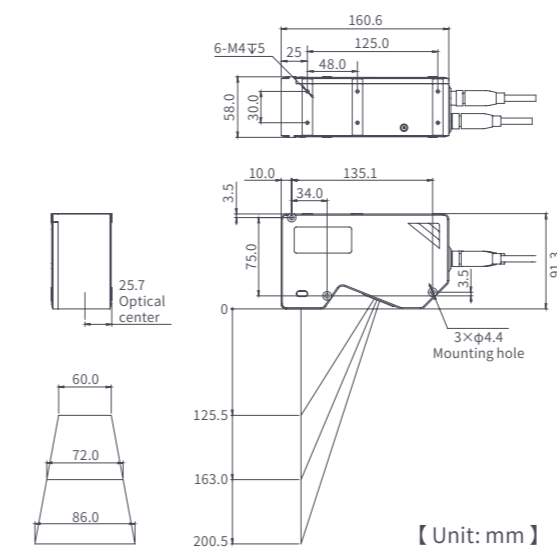
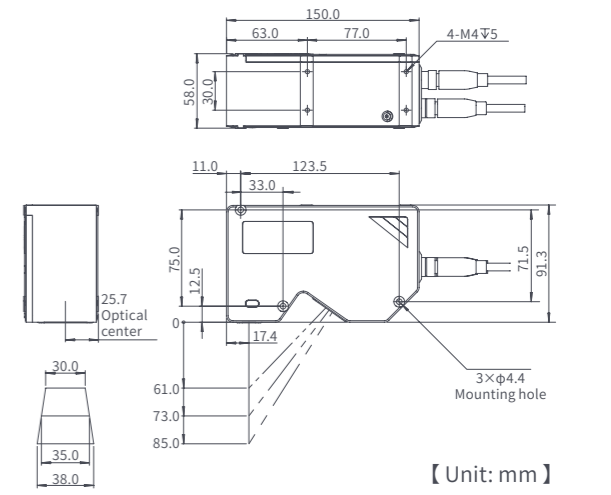
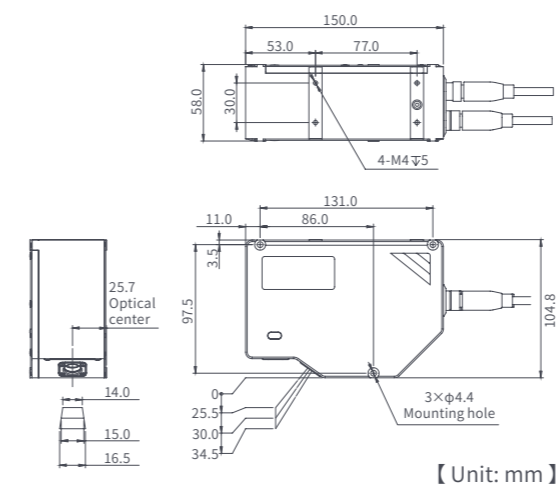
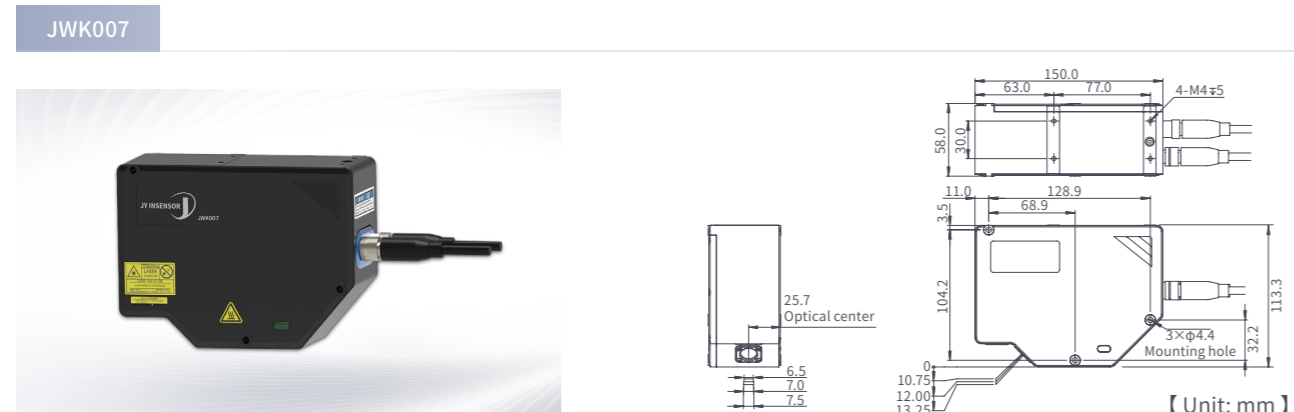

Circuit Diagram

Three differential signal pairs are internally converted to single-ended signals, transmitting encoder phase and revolution data to the processing chip. The differential signals are compatible with RS-422 voltage levels.

When NPN output mode is selected, connect the load according to the reference circuit.

When PNP output mode is selected, connect the load according to the reference circuit.

By controlling the optocoupler emitter, the circuit connected to the receiver can be controlled in an isolated manner.

The multi-function input signal polarity (NPN/PNP) is configured via software, used to detect external NPN/PNP input signals.

Pin Arrangement

Pin	Color	Function	Power signal connector pin arrangement
1	Brown	INPUTX_A	
2	Blue	Reserved	
3	White	INPUTX_B	
4	Green	INPUT2	
5	Pink	INPUTY_A	
6	Yellow	INPUT1	
7	Black	INPUTY_B	
8	Gray	IOOUT1	
9	Red	INPUTZ_A	
10	Purple	IOOUT2	
11	Red-Blue	INPUTZ_B	
12	Brown/Green	MFL_OUT	
13	Gray/Red	Reserved	
14	White/Gray	0 V	
15	White/Yellow	+Ub	
16	White/Green	0 V	
17	Yellow/Brown	+Ub	
Shell	Shell (Shield)		

Pin	Color	Network connector pin arrangement
1	White/Orange	
2	Orange	
3	White/Green	
4	Green	
5	White/Blue	
6	Blue	
7	White/Brown	
8	Brown	

JSL Series 3D Snapshot Sensor



JSL-Nano 3D Snapshot Sensor High-Frequency Response Fast Measurement







Product Overview

JSL-NANO is a compact binocular structured light sensor for industrial guidance and positioning in confined spaces. Combining binocular vision and structured light projection, it captures 3D data of target objects under 2 seconds, providing precise positioning and automation guidance.



Technical Advantage

- 
Binocular Structured Light Technology
 Provides stable and reliable 3D measurement capability
- 
Fast Response
 Typical acquisition time of 0.6–1.1s ensuring real-time performance
- 
High Repeatability
 Achieves a repeatability of 0.1 mm at the reference distance
- 
Miniaturized Design
 Compact form factor ideal for space-constrained environments
- 
Wide Measuring Range
 ± 150 mm measuring range to meet diverse application needs
- 
Outstanding Linearity
 Delivers 0.1% of F.S. accuracy

Application Scenarios

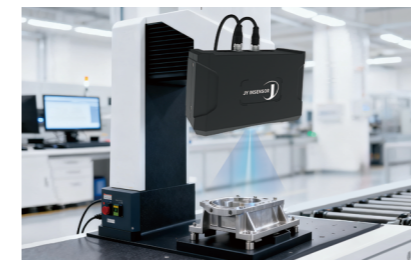

Precision Manufacturing
Applicable to microelectronics, precision machinery, and medical components for micron-level positioning and assembly accuracy.



Intelligent and Special Scenarios
Ideal for small robotic vision positioning systems and measurement or guidance in confined spaces, breaking through environmental limitations



Research Support
Empowers research institutions in 3D measurement and positioning studies, providing high-precision data for scientific research and innovation

Performance Specifications

Model	JSL-NANO
Measuring range	±150 mm
Reference distance	450 mm
Field of view at reference distance	330 mm×260 mm
Field of view at 300 mm (near)	220 mm×170 mm
Field of view at 600 mm (far)	450 mm×350 mm
Z-axis repeatability (at reference distance)	0.1 mm
Linearity	±0.1% of F.S.
Typical Acquisition Time	0.6 s-1.1 s
Light Source	Blue semiconductor laser (445 nm)
Laser Class	CLASS 3R
Communication Interface	1000BASE-T
Protection class	IP67
Voltage Range	11-30 VDC
Operating Temperature	0-45 °C

※ Notes:

1. The measurement target is a standard diffuse reflective object.
2. Use height/position tools to measure within the initial setup area.
3. Values are obtained after smoothing and averaging.
4. Data are averaged at the reference distance.

Dimensions Diagram

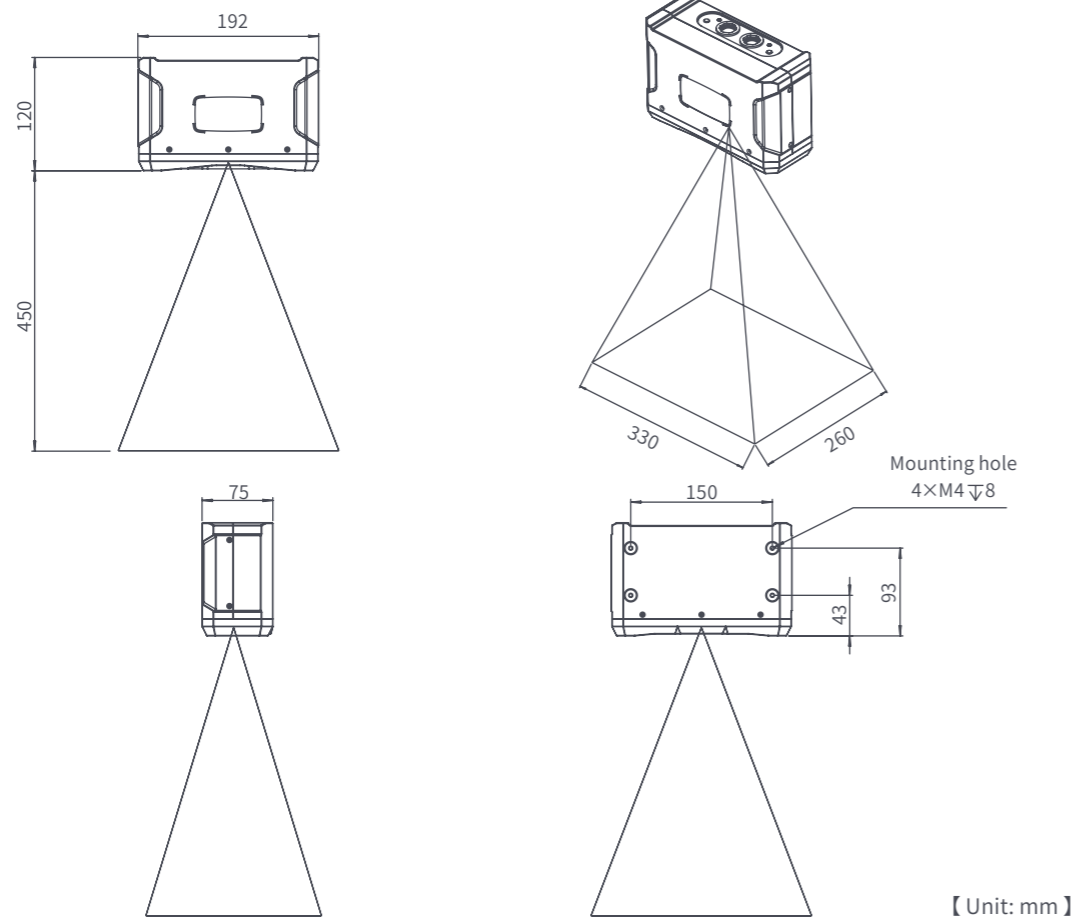

Product Appearance



Circuit Diagram

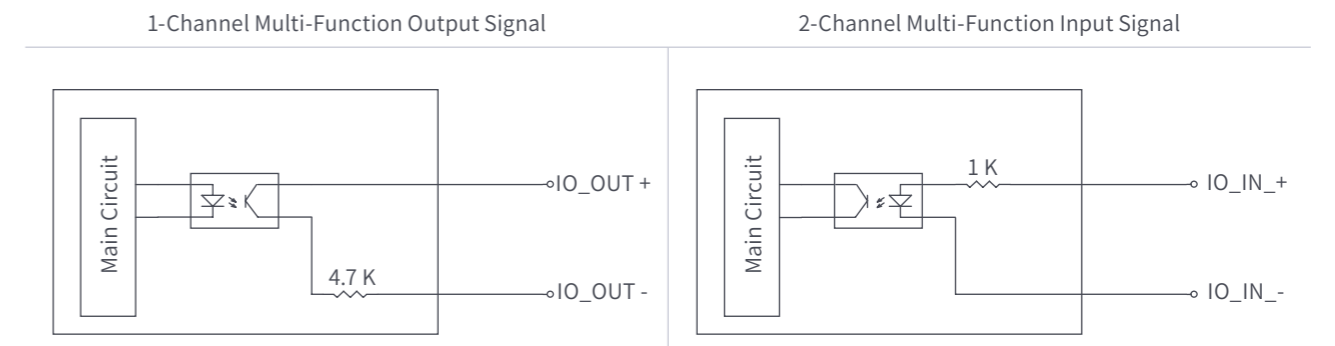

Pin Arrangement

Pin	Color	Function	Aviation connector pin arrangement
1	White	+Ub	
3	Green	0V	
5	Gray	IO_IN_2-	
6	Blue	IO_IN_2+	
7	Red	IO_OUT+	
8	Pink	IO_OUT-	
9	White/Green	IO_IN_1-	
10	Purple	IO_IN_1+	
11	Blue/Red	485B	
12	Black	485A	

Pin	Color	Network connector pin arrangement
1	White/Orange	
2	Orange	
3	White/Green	
4	Green	
5	White/Blue	
6	Blue	
7	White/Brown	
8	Brown	



Tianjin Jinya Elektronik GmbH

Germany: European Representative Office
Address: Marie-Curie-Str. 6, 85055 Ingolstadt, Germany
Business Cooperation: support@jyinsensor.com
Official Website: www.jyinsensor.com

■ Japan: Group Headquarters

Company: Three E Science Co.,LTD.
Address: Grand Green Osaka North Tower, 6-38-704 Ofukacho, Kita-ku, Osaka, 530-0011, Japan

■ U.S.A.: Global Innovation Center

Company: JY AutoIntel Inc.
Address: 1590 Oakland Rd, Suite B112, San Jose, CA 95131, USA

■ Global Manufacturing Bases (Strategic Production)

China Base:
Tianjin: No. 95 Nanhai Road, TEDA, Tianjin, China, 300457
Shanghai: Building 28, No. 3255, Shengang Road, Songjiang District, Shanghai, China

Vietnam Base (JY AUTOINTEL VIET NAM):
Address: Factory A1, No. 05, Road 21A, VSIP Bac Ninh, Bac Ninh Province, Vietnam